



SDH 370.55LIKT / 5500 kg
SDH 370.70LIKT / 7000 kg

Modello equipaggiato con **4 bracci extra lunghi a tre stadi**: ideali per il sollevamento di **furgoni e furgonati a passo lungo** incluso Mercedes Sprinter e VW Crafter.

*Model equipped with **four extra long three-stage arms**: ideal to lift **long wheel-base vans** like Mercedes Sprinter and VW Crafter.*

Modell mit **vier zweifach ausziehbaren extra langen Armen** ausgestattet: ideal zum Heben von Lieferwagen auch mit langem Radstand wie Mercedes Sprinter and VW Crafter.

*Elévateur équipé de **quatre bras extra longs à 3 étages**: idéal pour le levage de fourgons à **châssis long** inclus les Mercedes Sprinter and VW Crafter.*

Modelo equipado con **4 brazos extra largos de tres extensiones**: ideal sea para el levantamiento de furgonetas normales y de chasis largo incluido Mercedes Sprinter and VW Crafter.

Dispositivo di appoggio meccanico ad inserimento automatico a garanzia della massima sicurezza in fase di stazionamento.

Mechanical safety latch with automatic engagement ensuring maximum safety when lift is in standing position.

Mechanische Stützvorrichtung mit automatischer Einschaltung um eine maximale Sicherheit im aufgehobenen Zustand zu garantieren.

Dispositif de soutien mécanique avec enclenchement automatique pour garantir la sécurité totale pendant le stationnement.

Dispositivo de apoyo mecánico de funcionamiento automático como garantía de la máxima seguridad en la fase de estacionamiento.

I cavi non portanti garantiscono la sincronizzazione.

Synchronization cables grant the levelling of the two carriages.

Gleichlauf mittels Seile (nicht tragend).

La synchronisation est garantie grâce à un câble d'acier non-portant.

Los cables no portantes garantizan la sincronización.

In ciascuna colonna è presente un pistone di sollevamento che non richiede alcuna manutenzione.

Each column features a maintenance-free lifting cylinder.

Wartungsfreie Zylinder in jeder Säule.

Chaque colonne est équipée d'un vérin conçu pour un fonctionnement "sans entretien".

En cada columna está presente un pistón de elevación que no requiere mantenimiento alguno.



Due colonne elettroidraulici

(IT)

Electro-hydraulic 2 post lifts

(EN)

Elektrohydraulische 2-Säulen Hebebühnen

(DE)

2 Colonnes électro-hydrauliques

(FR)

Dos columnas electro-hydraulicas

(ES)



Altezza regolabile
Adjustable height
Justierbare Höhe
Hauteur réglable
Altura regulable

SDH370.55LIKT
4950 mm
4850 mm



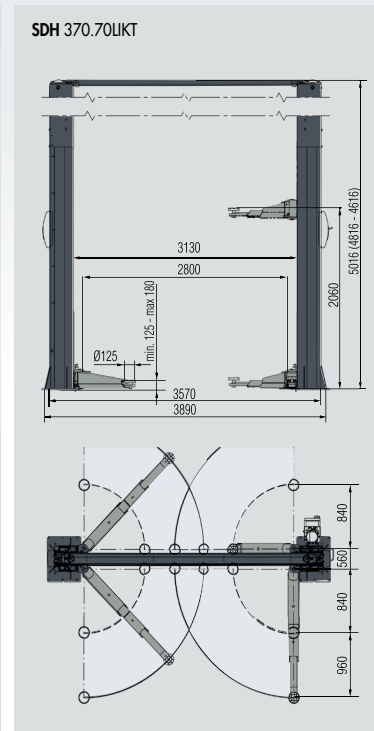
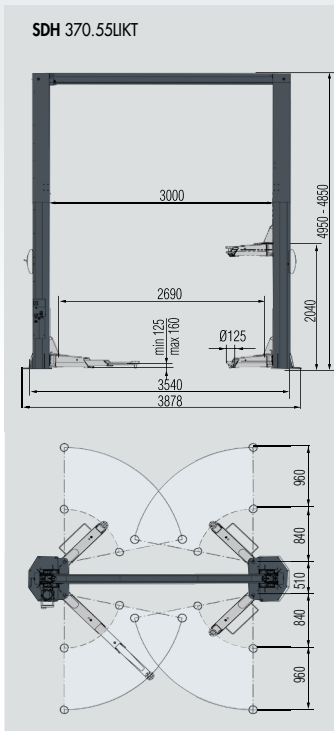

SDH370.70LIKT
5016 mm
4816 mm
4616 mm

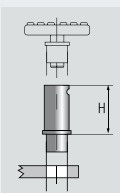

VARSDH370.55LIKT/T - VARSDH370.70LIKT

1	Versione a richiesta con: Comando singolo per salita/discesa	Version on demand featuring: Single lifting/lowering control	Version auf Anfrage: Drehwendschalter zum Hoch-und Runterfahren	Version sur demande avec: Commande unique pour montée-descente.	Versión bajo pedido con: Mando individual para bajada/subida
2	Sgancio arresti pneumatico	Pneumatic release of locking devices	Pneumatische Entriegelung	Décrochage pneumatiques des arrêts.	Desenganche neumático de los trinquetes de seguridad
3	Centralina in alto.	Control unit on the upper part of the column.	Hydraulikaggregat oben.	Unité hydraulique en haut.	Centralita posicionada en la parte alta de la columna.

OPTIONS

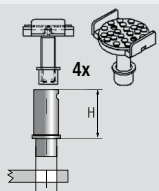
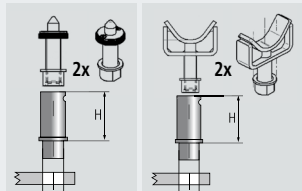
SDH370.55LIKT	S224A3	S224A4	S370A18	S370A19	S370A17
SDH370.70LIKT	S370A7 (H=80mm)	S370A8 (H=140mm)	S370A15 (H=200mm)	S370A16	S370A14
					
	For Fiat Ducato, Peugeot Boxer, Citroën Jumper Distanziali Spacers Abstandstücke Rehaussses Espesores			Supporti presa telaio Frame adapters Halterungen für Chassisaufnahme Supports prise sur chassis Espesores de agarre sobre chasis	For Mercedes Sprinter, VW LT+Crafter Supporti Adapters Halterungen Supports Adaptadores de agarre

SPACE s.r.l. a s.u.

Via Sangano, 48
10090 Trana - Torino - ITALY
tel. +39-011-934.40.300
fax +39-011-933.88.64
e-mail: info@spacetest.com
www.spacetest.com



Le caratteristiche tecniche e gli allestimenti presentati in questo prospetto possono subire variazioni. Le immagini riprodotte non sono vincolanti.
Technical data and composition presented in this catalogue may vary. Pictures reproduced are only indicative.
Die techn. Daten und die Ausüstungen, die in diesem Prospekt enthalten sind, können Änderungen erfahren. Deshalb sind die Abbildungen unverbindlich.
Les caractéristiques techniques et les compositions présentées dans ce prospectus peuvent subir des variations. Les images reproduites n'ont qu'une valeur indicative.
Las características técnicas y las composiciones ilustradas en este folleto pueden sufrir variaciones. Las imágenes propuestas son solamente indicativas.

