

Models 315 and 315-EU Straight Line Air Sander - Exploded View

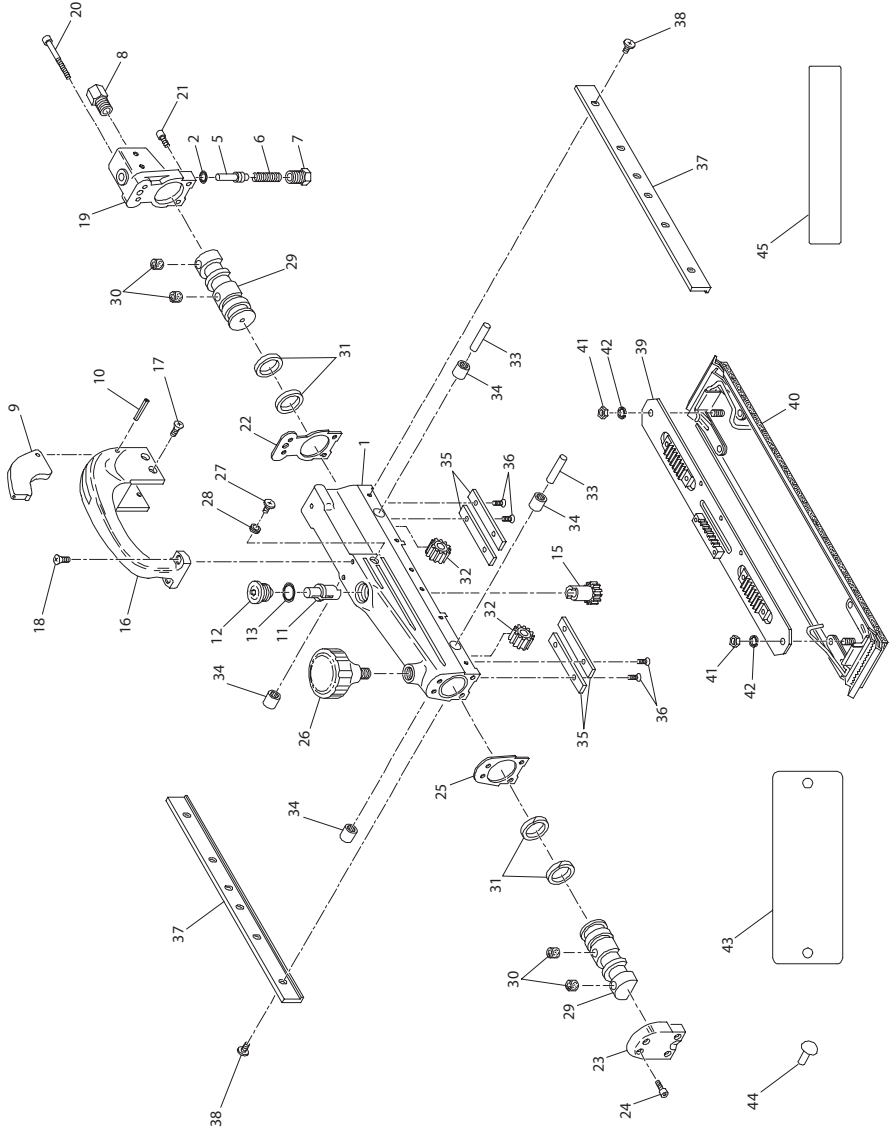

(Dwg. TPA990-3)

Models 315 and 315-EU Straight Line Air Sander - Parts List

Item	Part Description	Part Number	Item	Part Description	Part Number
1	Housing Assembly (includes reverse valve bushing)	315-A40	27	Oiler Cavity Screw	315-328
			28	Oiler Cavity Washer	315-329
2	Throttle Valve Seal	315-306	29	Piston Assembly (2)	315-A5
5	Throttle Valve	315-304	30	Felt Piston Plug (2 for each piston)	315-7
6	Throttle Valve Spring	315-305	31	Piston Seal Ring (2 for each piston)	315-6
7	Throttle Valve Spring Seat	315-103	32	Piston Pinion Gear (2)	315-9
8	Inlet Bushing	315-565	33	Piston Pinion Gear Shaft (2)	315-191
9	Throttle Lever	315-273	34	Pinion Gear Shaft Bearing (4)	315-24
10	Throttle Lever Pin	315-274	35	Wear Plate (4)	315-37
11	Reverse Valve	315-330	36	Wear Plate Screw (8)	315-324
12	Reverse Valve Cap Assembly	315-A331	37	Guide Plate (2)	315-36
13	Reverse Valve Cap O-Ring	315-332	38	Guide Plate Screw (12)	315-327
15	Reverse Valve Pinion	315-310	39	Drive Board (includes racks)	315-38
16	Rear Handle	315-59	40	Sanding Pad Assembly	315-39
17	Rear Handle Screw (4) (short)	315-320	41	Sanding Pad Nut (2)	315-323
18	Rear Handle Screw (2) (long)	315-326	42	Sanding Pad Lock Washer (2)	315-441
19	Backhead (includes throttle valve bushing)	315-A102	43	Nameplate	
20	Backhead Mounting Screw (2) (long)	315-325		for 315	315-301
21	Backhead Mounting Screw (2) (short)	315-321		for 315-EU	315-EU-301
22	Backhead Gasket	315-740	44	Nameplate Drive Screw (2)	222-302
23	Fronthead	315-240	45	Warning Label	
24	Fronthead Mounting Screw (4)	315-321		for 315	WARNING-5-99
25	Fronthead Gasket	315-739		for 315-EU	EU-99
26	Front Handle	315-48			

Parts and Maintenance

When the life of the tool has expired, it is recommended that the tool be disassembled, degreased and parts be separated by material so that they can be recycled.

Tool repair and maintenance should only be carried out by an authorized Service Center.

Refer all communications to the nearest **Ingersoll Rand** Office or Distributor.

Related Documentation

For additional information refer to:

Product Safety Information Manual 04584967.

Product Information Manual 80156177.

Manuals can be downloaded from www.ingersollrandproducts.com