

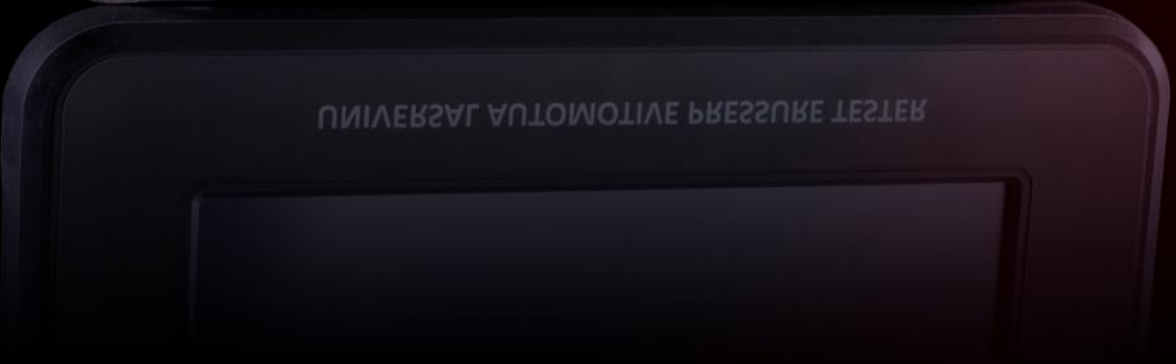

PressureDiag[®]
Universal Automotive Pressure Tester





PRESSURE DIAG

HU35025

Kit includes:

- 7" Color TFT display with resistive touch panel
- Sensor -1 to 3 bar
- Sensor 0 to 300 bar
- Universal Diesel compression adaptor
- Universal petrol compression adaptor
- 9 specific professional quick coupling adaptors
- Vacuum adaptors
- Battery : LiPo 3,7 V / 2000 mA
- PC connection by USB port
- ABS enclosure with rubber bumper (Hubitools design)

REPLACES **DOZENS** OF STANDARD DIAGNOSIS KITS IN JUST **ONE** SET

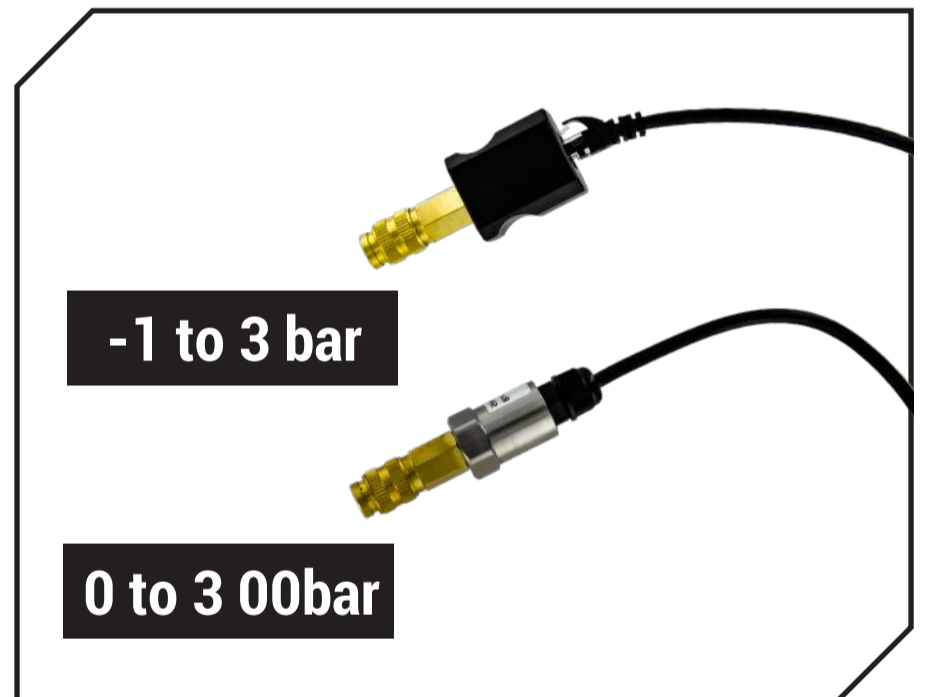

-1 to 3 bar

0 to 3 00bar

SAVE, EXPORT, PRINT AND SHARE YOUR **RESULTS !**



ALL APPLICATIONS YOU NEED



Vacuum pressure



AdBlue pressure



Compression PETROL & DIESEL



Oil pressure



Cooling system pressure



Particle filter pressure



Fuel low pressure



Turbo pressure

DIESEL GLOW PLUG COMPRESSION ADAPTER

HU35039

- Universal false glow plug to be mounted in place of the OEM glow plug to perform a Diesel compression test.
- Simply select the right thread adaptor and the right sealing cone to copy the OEM glow plug.

Kit includes :

- 4 screw-in adaptors (M8x1, M9x1, M10x1 and M10x1,25)
- 4 sealing cones (Ø 8.2/60°, Ø 8.2/90°, Ø 6.8/90°, Ø 6.8/120°)



THIS KIT REPLACES DOZENS OF COMPRESSION GLOW PLUGS ADAPTORS

DIESEL INJECTOR COMPRESSION ADAPTER

HU35037

- Universal false injector to be mounted in place of the OEM injector to perform a Diesel compression test.
- Copy the length and sealing part of the OEM injector using the different heads and spacers.
- Can be used either with the bridge included or with the OEM bridge.
- Also works for engines with one bridge for 2 injectors.



SCHRADER ADAPTERS

- These adapters allow to test fuel low pressure of engines using Schrader type connectors inlets for pressure testing (Ford, GM...).
- Also allow to test cooling system pressure on cars equipped with Schrader type coolant bleeding valve.

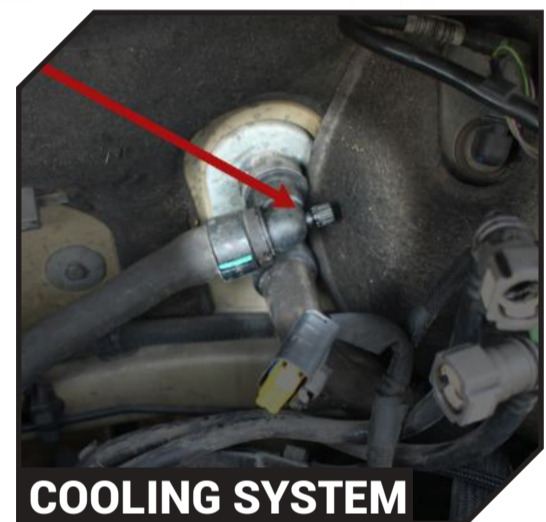
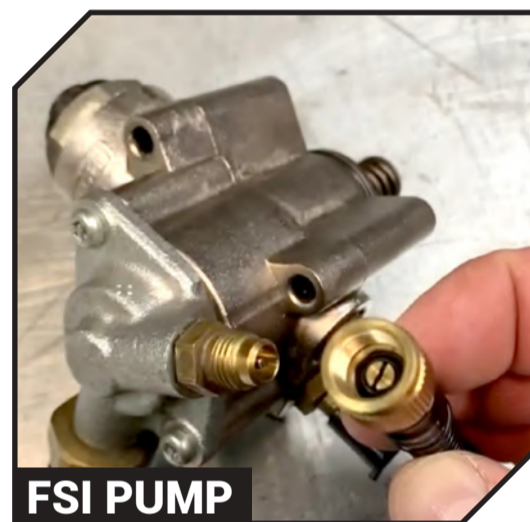
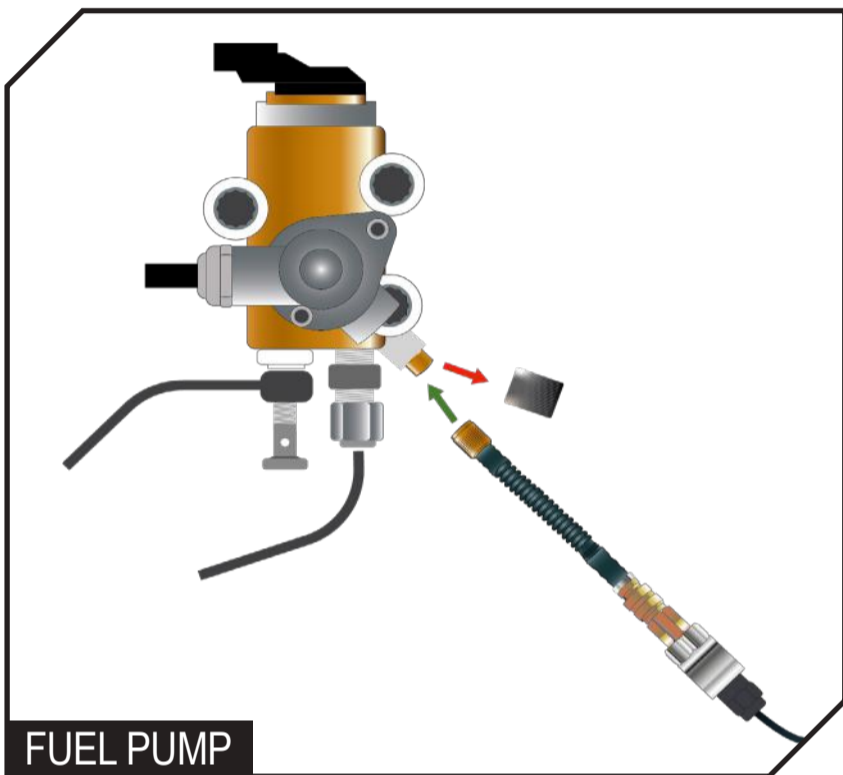

COOLING SYSTEM ADAPTER

HU35025-13

- This adapter can be used either along with the T adapters already included in the Pressure Diag or alone to perform a pressure test of the cooling system.
- Its design reproduces the OEM connection allowing it to connect to various spots in the cooling system. It helps locate an issue by bypassing some elements.
- Example of use : connect to the line that goes to :
EGR coolant port, radiator pressure release port, controlled thermostat port, coolant reservoir port, etc.



TEST MODERN COOLING SYSTEM

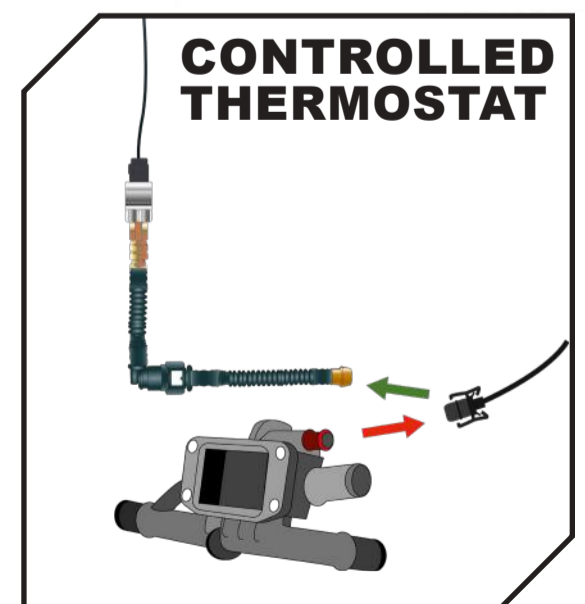

GASOLINE HIGH PRESSURE ADAPTERS

HU35029

- This kit allows, using the 0-300 bar sensor included in the Pressure Diag, to test the gasoline high pressure of most popular gasoline (petrol) engines (FSI, TFSI, TCe, T-Jet, etc.). Both using the sensor location or the dedicated plug location.
- Kit includes the following adapters :

HP1 = M12x150	HP4 = M10x100
HP2 = M12x125	HP5 = M8x100
HP3 = M14x150	



ONLY UNIVERSAL KIT IN THE MARKET

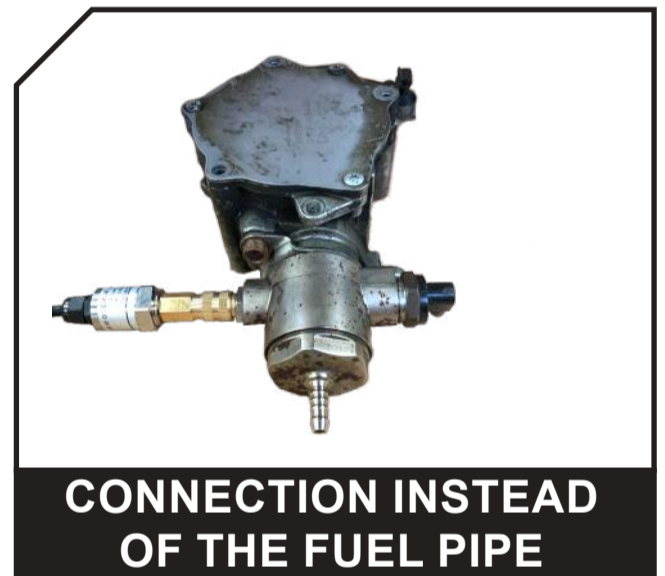
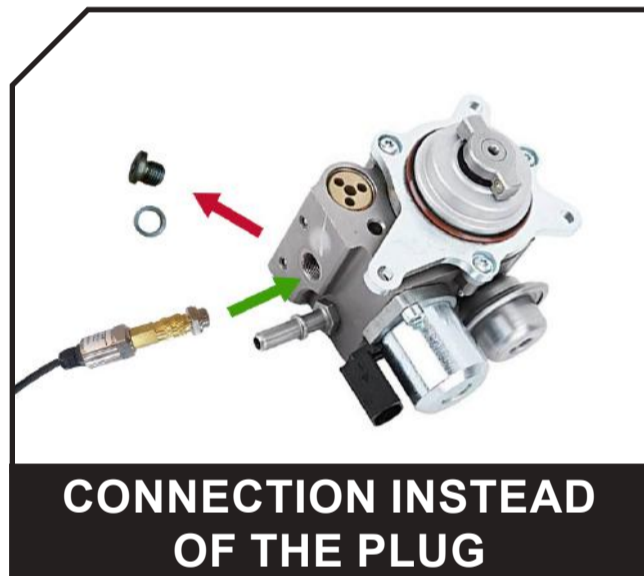
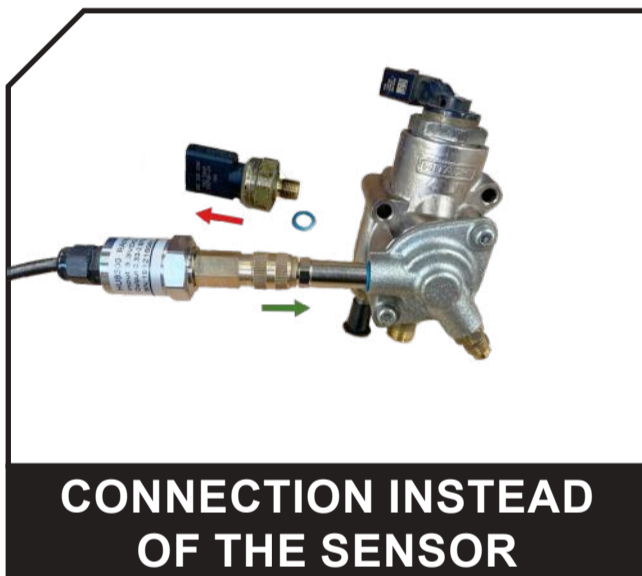

UNIVERSAL T ADAPTERS (2 PCS)

HU35041

- Those T-Fitting "Barb" adapters allow you to easily connect to any soft low pressure line on cars, trucks, tractors, etc. when there is no quick connector to fit the plastic T's included in the Pressure Diag kit.
- Fit soft lines from internal diameter from 6 mm to 15 mm
- Used along with the electronic sensors included in the Pressure Diag

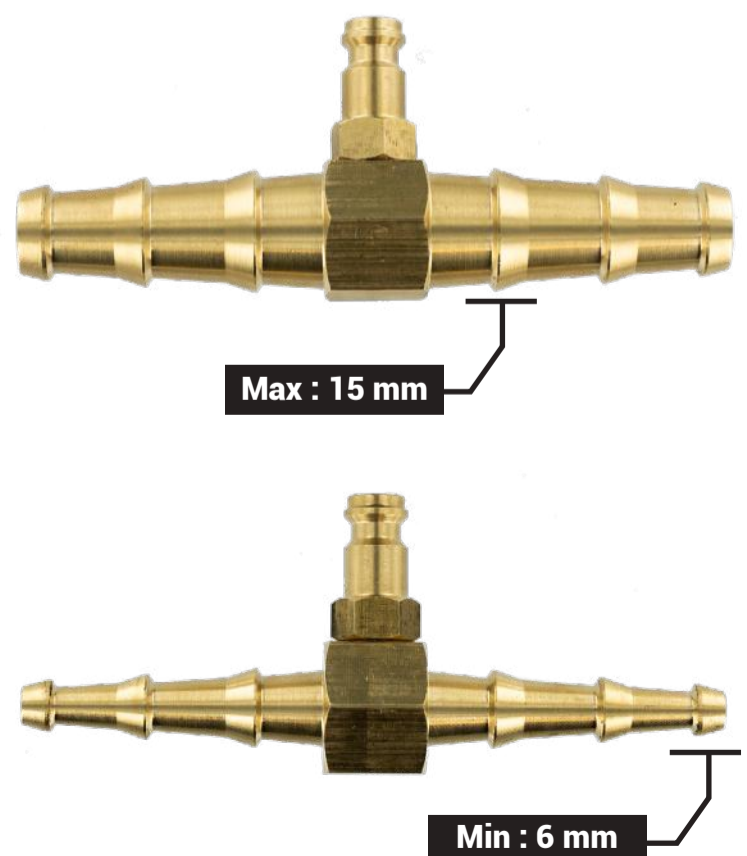

DIESEL HIGH PRESSURE KIT

HU35026

- Easily and safely test the diesel common rail pressure
- The mechanic will be able to safely test the diesel common rail pressure, both in line (in series with engine running) and for direct pump pressure (cranking the engine).
- Unlike simply having the pressure information with the sensor of the car (this sensor may have an issue), our set provides all the hardware (special sensor, plugs, hoses) to perform a very precise and accurate test in association with our digital Pressure Diag. The hoses in the set allow measurement and diagnosis of most usual common rail engines.
- Kit includes a 2000-bar sensor, a sensor plug for direct pump pressure, 2 hoses M12x150 for most common applications and a retrieving reservoir.

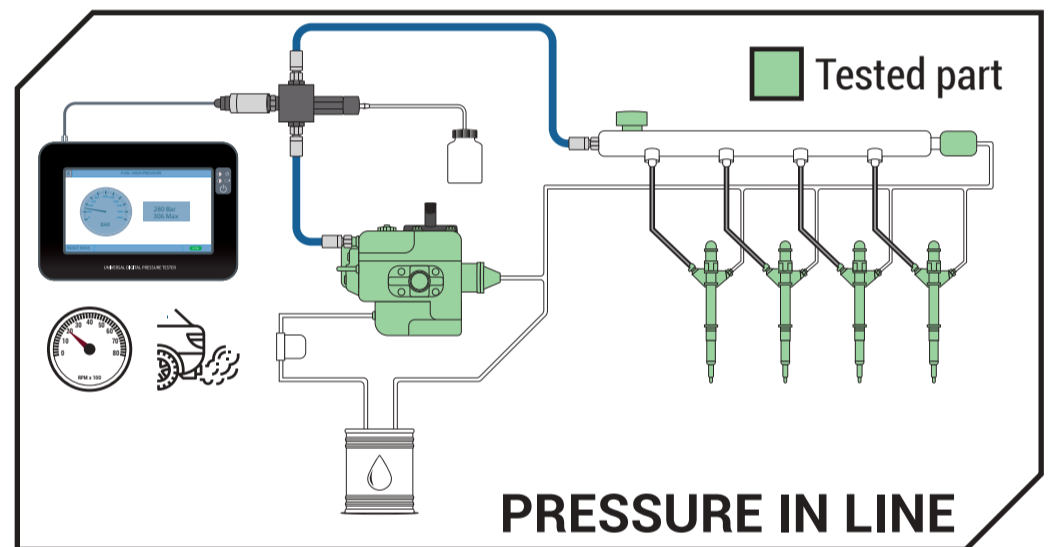
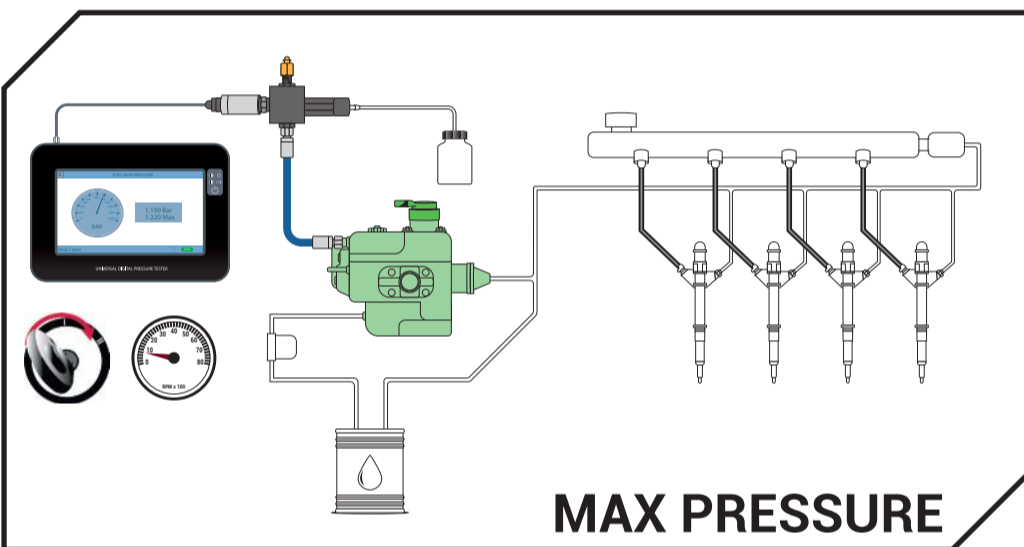

LAST GENERATION DIESEL ADAPTERS

HU35028

- This set, in association with the diesel high pressure kit, will allow to test the diesel high pressure of most popular cars in the market (Delphi, Siemens, Bosch and Denso pumps).
- One end of the adapters always has a M12x150 thread to fit our hoses. The other ends are :
 - M12x125 (2 pcs)
 - M14x150 (2 pcs)
 - M14x100 (1 pc)
 - M16x100 (1 pc)



COMMON RAIL DUMMY REGULATOR SET

HU35031

- This set, used in association with Diesel high pressure kit, allows to bypass the pump's regulator and measures the pressure to diagnose any regulator or pump issue.
- After observing the weak pump pressure, simply remove the regulator and choose the right dummy plug to bypass and seal the port. If the pressure comes back to normal, the regulator causes the pressure loss. If the pressure stays too low, the pump is defective. This test is recommended by manufacturers of high-pressure pumps.
- Kit includes 8 different dummies to seal any regulator ports.

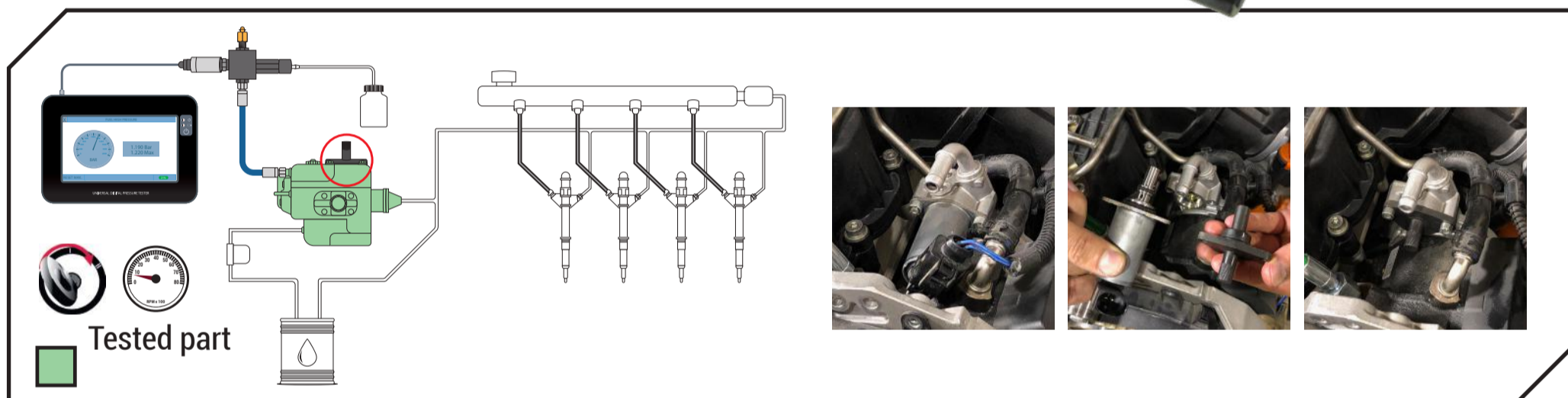

COMMON RAIL CAPS SET

HU35030

- Used in association with Diesel high pressure kit, this set will allow the closure of the injector's fuel inlets directly on the common rail. The purpose of this operation is to identify if an injector is leaking or not.
- Works for 3, 4, 5 and 6 cylinders engines.
- Kit includes 6 plugs M12x150 and 6 plugs M14x150.

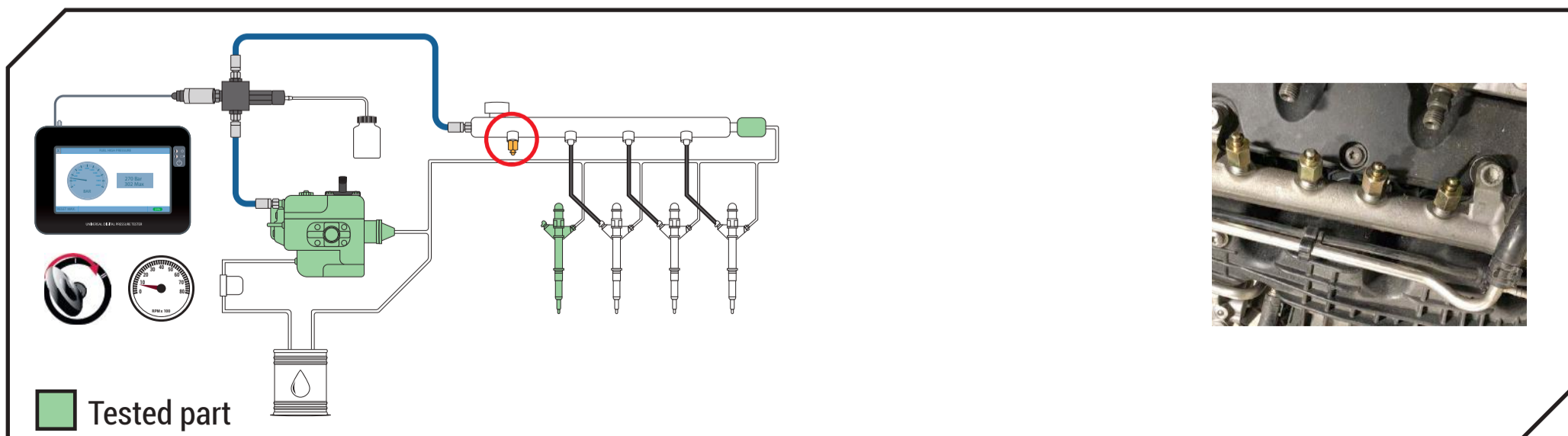

CYLINDER LEAKAGE TESTER

HU35027

Do you know what downsizing is?

Producing smaller engines that generate the same power!

Problems : even small differences in compression can significantly affect the behavior of these engines.

The cylinder leakage test is therefore unavoidable !

- Connects either directly to the Pressure Diag or to the pressure gauge, which is included, for stand-alone use.
- Ideal for warranty and traceability purposes with the ability to save and print the test reports.
- Delivered with M14, M12 and M10 petrol fittings.
- Connects to all Pressure Diag gasoline and diesel compression fittings.



CYLINDER LEAK TEST FOR A BETTER COMPRESSION DIAGNOSTIC

THE COMPRESSION TEST WILL QUICKLY TELL YOU WHICH CYLINDER IS THE PROBLEM

THE LEAK TEST WILL QUICKLY TELL YOU WHAT THE PROBLEM IS (INTAKE, EXHAUST...)

SAVE AND SHARE THE TEST RESULTS

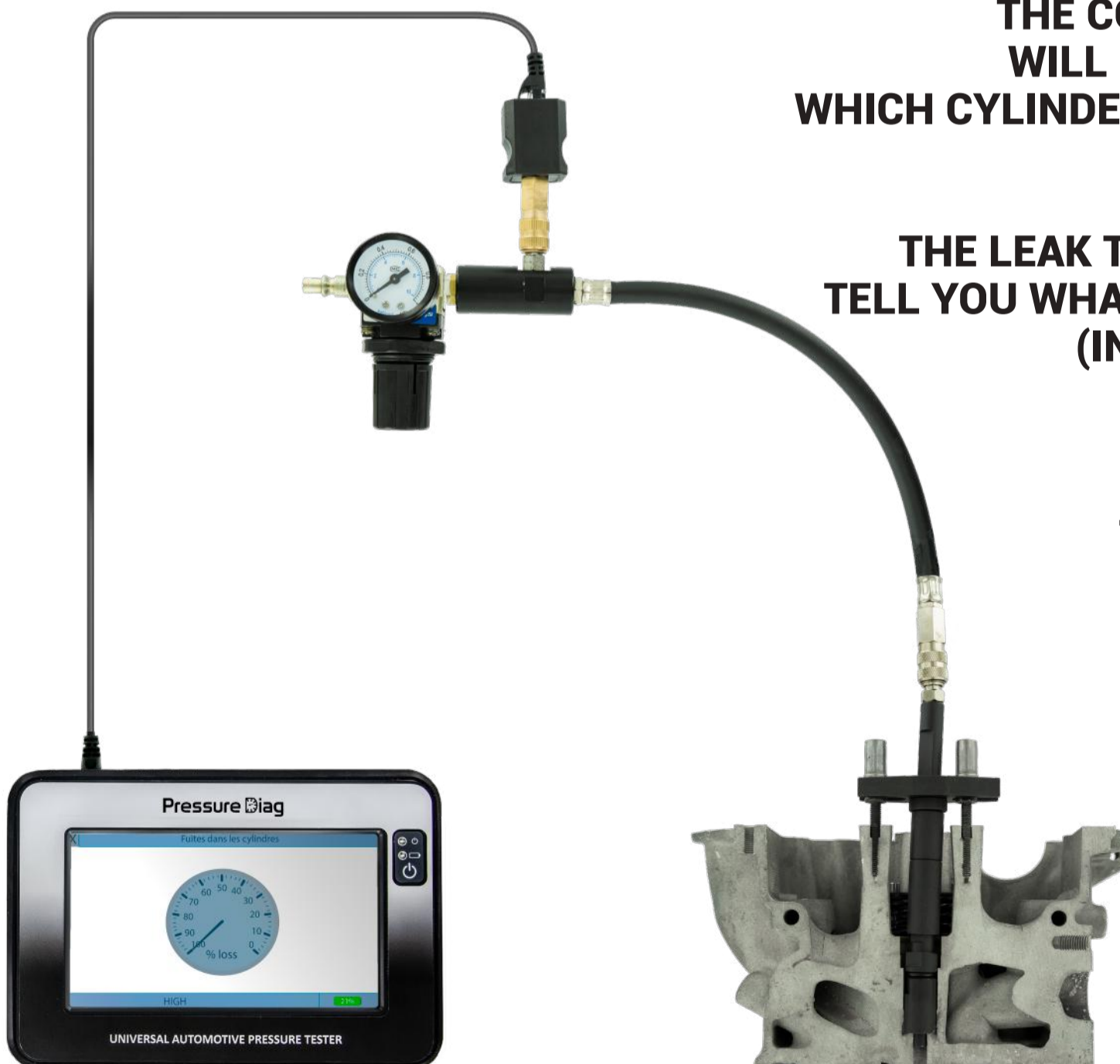

ENGINE & TURBO OIL PRESSURE ADAPTERS SET(15 PCS)

HU35033

- This kit allows, using the 0 - 300-bar sensor included in the Pressure Diag kit, to test the engine & turbo oil pressure of most popular engines.
- 10 adapters to fit most of the oil pressure sensors
- 4 adapters fit the most turbo banjo
- 1 x 90° quick connector



INCLUDING ADAPTERS TO MEASURE THE OIL PRESSURE DIRECTLY ON THE TURBO

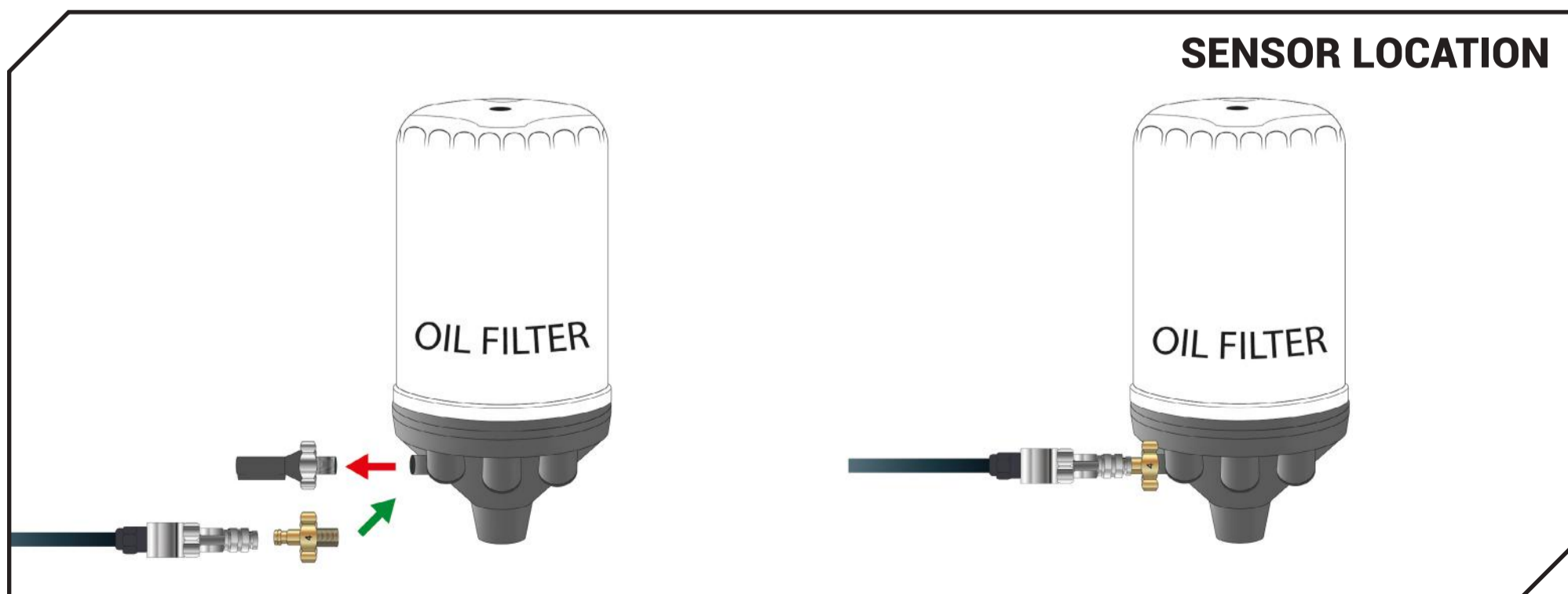
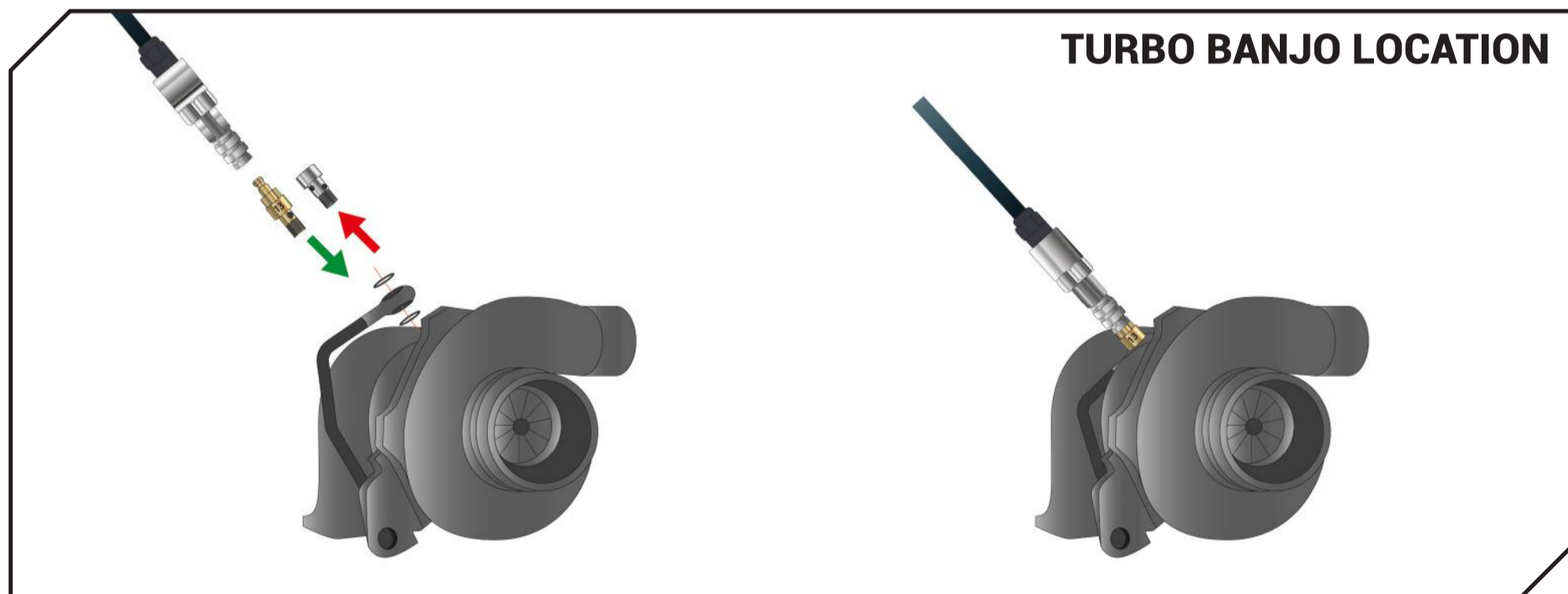

Hubitools
INNOVATIVE TOOL EXPERTS

WWW.HUBITOOLS.COM
CUSTOMER.SERVICE@HUBITOOLS.COM
+32 (0) 10 42 03 85

