

# Air hydraulic garage jacks



Its more compact design (short chassis) provides a better manoeuvrability and ease of use, however the models of the previous page (long chassis) provide a greater depth of access under the vehicle.



N15-2C

N25

N15-2BC

N35C

A-5204  
Optional.



A-5206  
L=50mm  
Optional.



NP15-2B/1866  
L=100mm  
Standard.

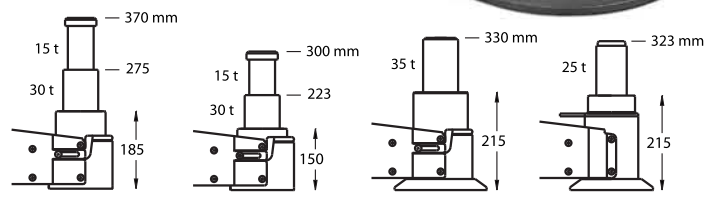

Capacity(t)	15-30	15-30	35	25
A	600	600	600	560
B	185	150	115	108
C	470	400	430	423
D	157	157	157	157
E	280	280	280	280
Weight (kg)	45	42	51	47
References	N15-2C	N15-2BC	N35C	N25

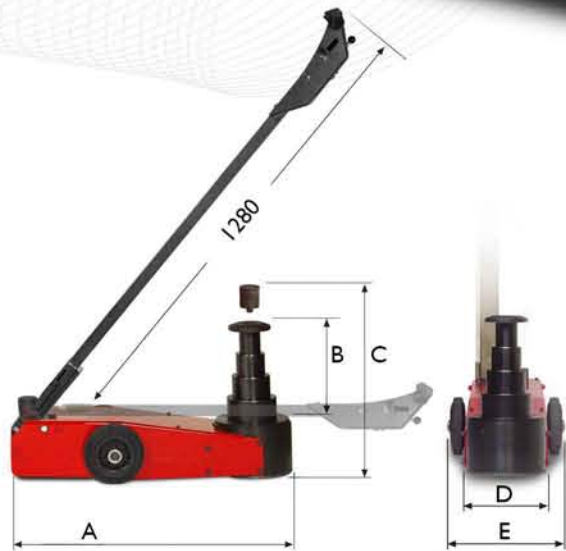

# Portable air jack



The telescopic lever has three positions:

- 1,2- For moving the jack.
- 3- Position for working.

Weight: 31 kg

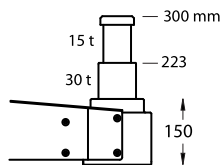

## ¡NEW MODEL!

Identical technology, concept and performance as our N 15 -30 model (same engine, same hydraulic block, etc)

The unique difference is that we have integrated the deposit into the frame so as to make it more compact, and to make the chassis extraordinarily robust and rigid. Without resorting to aluminium, so as not to reduce the strength of the jack and its useful life, we have achieved that the jack is an excellent weight while maintaining its exceptional load capacity for its category, 15 - 30 t.

The most compact, robust and practical model in the market.

